

# *KS stainless steel flanged gate valve*



## PRODUCT OVERVIEW

|                        |   |
|------------------------|---|
| Body material:         | CF8   |
| Size range:            | DN50~200  |
| Pressure rating:       | 1.0MPa  |
| Operating temperature: | -29 ~ 150°C   |
| End connection:        | Flanged   |
| Applicable medium:     | Water, Steam, Oil, Nitric acid liquid   |
| Mode of operation:     | Manual  |
| Applicable industry:   | Chemical & Petrochemical, Oil & Gas, Mining & Minerals, Power generation, Water & Water Treatment, Pulp & Paper, Municipal, Heating & Ventilation |
| Design & Manufacture:  | API, ASME, ASTM, ANSI, BS, DIN, JIS, ISO, GB  |

## DESIGN FEATURES

1. This is a flange valve, and implements the standard KS B 2361.
2. This valve is mainly composed of a valve body, a gate plate, a valve stem, a bonnet and a hand wheel. The valve stem moves up and down by turning the hand wheel, thereby driving the gate plate to rise or fall and make a linear displacement perpendicular to the fluid, so as to realize the function of opening and closing.

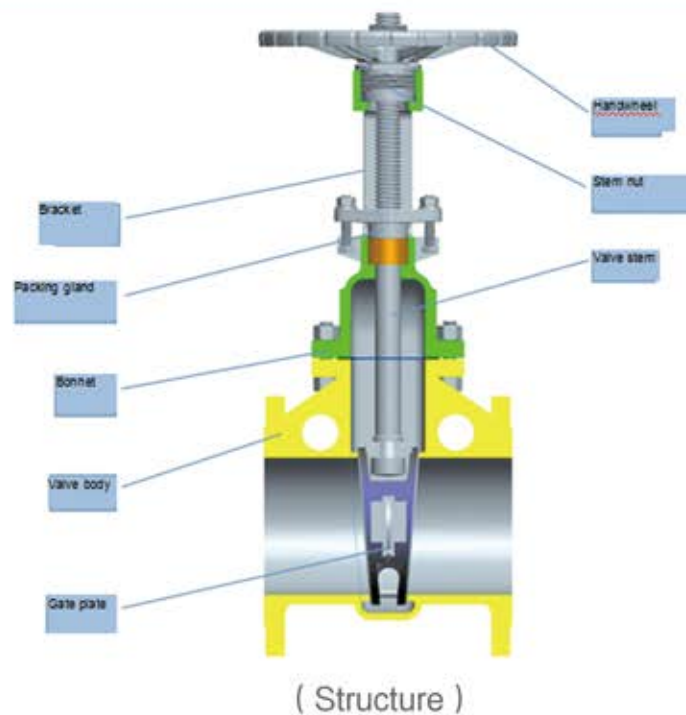

## VALVE MATERIAL LIST

| Part name                      | Material   |
|--------------------------------|------------|
| Valve body, gate plate, bonnet | CF8/CF8M   |
| Valve stem                     | F304       |
| Stem nut                       | ZCuAl10Fe3 |
| Packing                        | PTFE       |

## TECHNICAL SPECIFICATIONS

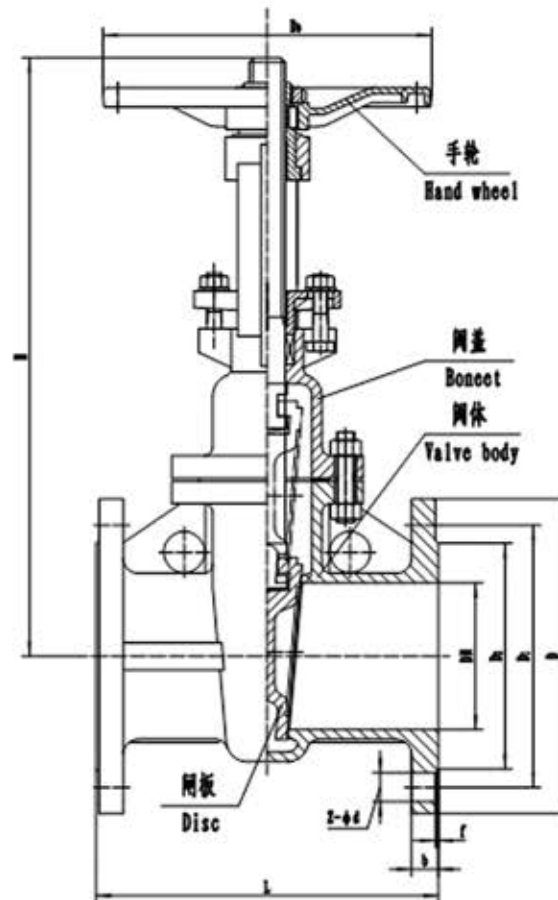

| Model                | DN (mm) | Size(mm) |     |                |                |      |        |      |       |                |
|----------------------|---------|----------|-----|----------------|----------------|------|--------|------|-------|----------------|
|                      |         | L        | D   | D <sub>1</sub> | D <sub>2</sub> | b-f  | z-φd   | Hmin | Hmax  | D <sub>0</sub> |
| Z41W-10P<br>Z41W-10R | 50      | 178      | 155 | 120            | 96             | 16-2 | 4-φ19  | 272  | 327   | 180            |
|                      | 65      | 190      | 175 | 140            | 116            | 18-2 | 4-φ19  | 297  | 267   | 180            |
|                      | 80      | 203      | 185 | 150            | 126            | 18-2 | 8-φ19  | 338  | 421   | 200            |
|                      | 100     | 229      | 210 | 175            | 151            | 18-2 | 8-φ19  | 400  | 507   | 200            |
|                      | 125     | 254      | 250 | 210            | 182            | 20-2 | 8-φ23  | 461  | 596   | 240            |
|                      | 150     | 267      | 280 | 240            | 212            | 22-2 | 8-φ23  | 559  | 722.5 | 280            |
|                      | 200     | 292      | 330 | 292            | 262            | 22-2 | 12-φ23 | 664  | 870   | 320            |